

2005 Escape

Index of Key Features

| | |
|---|--------------|
| What's New | 2 |
| What's Important | 3 |
| Model Lineup | 4-5 |
| Purchase Motivators | |
| Comfort/Convenience | 6-9 |
| Performance/Handling | 10-11 |
| Design/Styling | 12-13 |
| Safety/Security | 14-15 |
| Quality/Reliability/Durability | 16-17 |
| Reference | 18-32 |

Index of Key Features

| | | | |
|--|----------|--|-----------------|
| Accessories | 31, 32 | Illuminated Entry System | 15 |
| Accessory Delay Feature | 8 | Instrument Cluster | 20 |
| Airbag Supplemental Restraint System (SRS), Dual-stage Driver and Right Front Passenger | 15 | Instrument Panel | 6, 7 |
| Audio | 6, 9, 18 | Intelligent 4WD System | 10 |
| Premium AM/FM Stereo/Single-disc CD Player | | Interior Volume | 6, 7 |
| Premium AM/FM Stereo/Cassette/Single-disc CD Player | | Lower Anchors and Tethers for CHildren (LATCH) | 14 |
| Premium AM/FM Stereo/6-disc In-dash CD Player | | Message Center | 6 |
| MACH® 300 Audio System with Premium AM/FM Stereo/ 6-disc In-dash CD Player with Sirius Satellite Radio Capability | | New Vehicle Limited Warranty | 16, 17 |
| Auto Headlamp Off | 8 | No Boundaries™ Rack System | 12, 13 |
| Battery Saver | 15 | Occupant Classification Sensor | 14, 15 |
| Belt-Minder™ System | 14 | 100,000-mile Scheduled Tune-up Interval | 16, 17 |
| Black Step Bars | 12, 13 | Overhead Consoles | 8 |
| Body Structure | 13 | Personal Safety System™ | 14 |
| Bumpers | 12, 13 | Power Features | 8 |
| Cabin Air Filter | 6 | Rear-door Child Safety Locks | 15 |
| Cargo Area | 7 | Reclining Front Seats | 6 |
| Cargo Convenience Group | 7, 9 | Remote Keyless Entry System | 14 |
| Climate Control System | 6 | Safety Belts | 14, 15 |
| Colors, Exterior and Interior | 13 | Safety Package | 14, 15 |
| Engines | 10 | “Safety Cell” Construction | 15 |
| Duratec 23 - 2.3L I-4 | | Seating | 6, 7, 9, 15, 20 |
| Duratec 30 - 3.0L DOHC V-6 | | SecuriLock® Passive Anti-theft System | 14 |
| Electronic Engine Controls | 16, 17 | Serviceability | 17 |
| Exterior Design | 12, 13 | Side Door Intrusion Beams | 14 |
| 5-passenger Seating | 6 | 60/40 Split Rear Seat | 6, 7 |
| Flip-up Rear Glass and Liftgate | 12, 13 | Smoker's Package | 8 |
| Flow-through Floor Console | 8 | Spare Wheel and Tire, Compact | 11 |
| Four-wheel Anti-lock Braking System (ABS) | 14 | Speed Control | 8 |
| Four-wheel Disc Brakes | 14 | Steering, Rack-and-pinion | 11 |
| Four-wheel Independent Suspension | 11 | Storage | 7, 8 |
| Front Adjustable Safety Belt D-rings | 9 | Suspension, Front and Rear | 11 |
| Front-wheel Drive | 11 | Theater Lighting | 14 |
| Fuel Pump Inertia Shutoff Switch | 15 | Tilt Steering Column | 7 |
| Fuel Tank | 11 | Towing Capacity | 11, 21, 22, 23 |
| “Green” Vehicle Features | 10 | Transmissions | 10 |
| | | Unibody Monocoque Construction | 12, 14 |
| | | Wheels and Tires | 11, 19 |

This page is about:

- Model/Series Availability
- Exterior Changes
- Interior Changes
- Functional Changes
- Safety Changes
- New Package Changes

What's New

The following pages will detail Escape's many outstanding features. Listed is an overview of what's changed for 2005 and additional mid-model year enhancements:

Model/Series Availability

- **New** Duratec 23 I-4 engine now available on XLT series
- Model line expanded to include XLT Sport FWD/4WD arrays (replaces XLT Appearance Package)
- Escape lineup now includes: XLS Manual/XLS/XLT/XLT Sport/Limited (FWD); XLS Manual/XLS/XLT/XLT Sport/Limited (4WD)

Exterior Changes

- New front and rear fascias
- New 15-inch (XLS) and 16-inch (XLT) aluminum wheels
- New round fog lamps and clear lens headlamps
- Colors added:
 - Sonic Blue Clearcoat Metallic
 - Silver Clearcoat Metallic
 - Norseia Blue Clearcoat Metallic
 - Titanium Green Clearcoat Metallic
 - Red Fire Clearcoat Metallic — now available on Limited series
 - Blazing Copper Clearcoat Metallic — **only** available on XLS Blast Package
- Colors deleted:
 - True Blue Clearcoat Metallic
 - Satin Silver Clearcoat Metallic
 - Aspen Green Clearcoat Metallic

Interior Changes

- New automatic transmission floor gearshift
- New flow-through center console; new larger/deeper cup holders with removable inserts, front storage bin and power point
- Color-keyed interior for XLT and Limited
- New cloth for XLT and new premium leather for Limited
- New message center located on instrument panel — standard on Limited; includes oil change reminder, fuel computer and message center warnings
- New look for cluster gauges: warm steel-color frames and white-faced gauges
- Driver and front passenger seats now include dual reclining function
- All models now include the 60/40 split rear seat as standard equipment
- **Available** upgraded MACH® Audio System
- Cigarette lighter and ashcup deleted — now available as a Smoker's Package from FCSD

Functional Changes

- New Duratec 23 - 2.3L I-4 engine — 153 horsepower (replaces 2.0L Zetec I-4 engine) — available with manual and automatic transmission

- The Duratec 23 - 2.3L engine is now available **on XLT for better value and fuel economy**
- Improved automatic shift quality
- New Intelligent 4WD System (replaces Control Trac® II)
- Anti-lock Braking System (ABS) now standard across all models
- Power four-wheel disc brakes now standard on V-6 4WD models

Safety Changes

- New Safety Package: Safety Canopy™ System is now offered in combination with front side airbags (optional on all models)
- New rear center head restraint and rear center 3-point safety belt
- New Personal Safety System™ — includes new dual-stage airbag system for driver and right front passenger seating positions, and adds new **Front Passenger Sensing System (FPSS)** to the passenger seat
- New full-size spare wheel and tire — optional on XLT, XLT Sport and Limited

New Package Changes

- XLS Blast Package:
 - 16-inch painted grey aluminum wheels
 - P235/70R16 OWL all-season tires
 - MACH 6-disc in-dash audio system with 7 speakers
 - Privacy glass
 - Warm steel-color center finish panel and floor shifter ring
 - Unique exterior color availability — Blazing Copper Clearcoat Metallic
- Cargo Convenience Group:
 - Retractable cargo area cover and new rear cargo storage bin are offered together in one convenient package — optional on all **series**
- XLT No Boundaries™ Package:
 - **No Boundaries dual Roof Rack System**
 - Unique interior finishes including new unique cloth fabric
 - New molded-in-color silver-finish front and rear appearance skid plates

Key Competitors and How They're Positioned

- **Jeep Liberty** — brand image of practical, versatile, affordable, rugged fun; an American classic
- **Chevy Equinox** — **brand image of sporty, playful, well designed and versatile**
- **Honda CR-V** — brand image of fun, versatility, comfort, convenience and sophistication
- **Hyundai Santa Fe** — marketed as exceptionally well-equipped and backed by America's best warranty

2005 Escape

What's Important

WHAT'S IMPORTANT

This page is about:

Product Highlights —

Key Features —

Product Highlights

HERE ARE THE **MOST IMPORTANT** 2005 ESCAPE FEATURES TO MENTION TO YOUR CUSTOMERS:

**5-passenger seating
with outstanding
cargo flexibility**
(pg. 6)

**Safety Package
with Safety
Canopy™ System
and side airbags**
(pgs. 14, 15)



**Choice of
Duratec 23 - 2.3L I-4
or Duratec 30 - 3.0L
V-6 engines**
(pg. 10)

**Intelligent
4WD System**
(pg. 10)

Key Features

Use the Escape information in this Source Book to enhance your sales presentations. Pay particular attention to those key features that address the specific needs of your customers. Refer to your Dealer Ordering Guide for specific feature availability.

Comfort/Convenience

- 60/40 split rear seat with fold-flat feature
- **5-passenger seating**
- Automatic transmission floor gearshift
- Flow-through floor console with larger, deeper cup holders, additional front storage bin and 1 power point
- AM/FM stereo/single-disc CD player/clock (XLS Manual, XLS)
- AM/FM stereo with 6-disc in-dash CD player (XLT, XLT Sport and Limited)
- **Cargo Convenience Group**

Performance/Handling

- Front-wheel drive
- **Intelligent 4WD System**
- **Duratec 23 - 2.3L I-4 engine with 5-speed manual transmission (XLS Manual) or 4-speed automatic overdrive transmission (XLS and XLT)**
- **Duratec 30 - 3.0L DOHC V-6 engine with 4-speed automatic overdrive transmission (XLT, XLT Sport and Limited)**
- Four-wheel independent suspension
- Class II Trailer Towing Package available with V-6 engine (3500-lb. maximum towing)⁽¹⁾

Design/Styling

- Classic "Ford Tough" SUV styling
- Unibody monocoque construction
- Rear liftgate with flip-up rear glass
- 15- and 16-inch wheels and tires
- XLT No Boundaries™ Package
- **Limited series for refined monochromatic look**

Safety/Security

- Four-wheel Anti-lock Braking System (ABS) — standard
- Personal Safety System™ with dual-stage airbag system for driver and front passenger seating positions, and **Front Passenger Sensing System (FPSS)** including a passenger-seat weight sensor for the front passenger seat
- **Safety Package with Safety Canopy™ System and dual front side airbags (optional)**
- LATCH feature (Lower Anchors and Tethers for CHildren)
- Remote Keyless Entry System

Quality/Reliability/Durability

- Easy access to key components under the hood
- 100,000-mile scheduled tune-up interval
- Worldwide testing
- New Vehicle Limited Warranty and Ford Roadside Assistance Program

(1) Properly equipped.

MODEL LINEUP

This page is about:

Escape XLS

2005 Escape Model Lineup

Escape XLS



COMFORT/CONVENIENCE

- Power windows, locks and mirrors
- Remote Keyless Entry System
- AM/FM stereo/single-disc CD player/clock with 4 speakers
- Air conditioning
- Tilt steering wheel
- Cloth sun visors with dual vanity mirrors
- Cloth front low-back bucket seats with head restraints
- Cloth 60/40 split rear seat
- Illuminated Entry System
- Liftgate/liftglass with 2-speed wiper
- Flow-through floor console with large cup holders, storage bin and power point

PERFORMANCE/HANDLING

- Duratec 23 - 2.3L I-4 engine
- 5-speed manual transmission (XLS Manual)
- 4-speed automatic transmission (XLS)
- Four-wheel independent suspension
- Front-wheel drive or **Intelligent Four-Wheel Drive**
- Power rack-and-pinion steering
- P225/75R15 BSW all-season tires

DESIGN/STYLING

- 15-inch 5-spoke styled-steel wheels
- Black grille surround with black mesh center
- Cluster gauges: Warm steel-colored frames and white-faced gauges
- Molded-in-color Grey front and rear fascias and bodyside cladding
- Clear lens headlamps
- Roof side rails

SAFETY/SECURITY

- Personal Safety System™ with Driver and Front Passenger Dual-stage Airbag SRS and **Front Passenger Sensing System (FPSS)** for front passenger seat
- SecuriLock® passive anti-theft system
- LATCH feature (Lower Anchors and Tethers for CHildren)
- Belt-Minder™ System
- Front- and rear-seat adjustable head restraints including rear center position
- "Safety cell" construction
- 3-point safety belts including rear center position
- Four-wheel Anti-lock Braking System (ABS)
- Side door intrusion beams

QUALITY/RELIABILITY/DURABILITY

- Unibody monocoque construction
- Rear suspension built-in alignment cams
- 100,000-mile scheduled tune-up interval
- Extended-life transmission fluid (automatic only)

2005 Escape

Model Lineup

MODEL LINEUP

This page is about:

- Escape XLT —
- Escape Limited —

Escape XLT



COMFORT/CONVENIENCE

Includes all the features of Escape XLS plus the following additions or upgrades:

- AM/FM stereo/6-disc in-dash CD player/clock with 4 speakers
- Premium cloth front low-back bucket seats with driver and passenger map pockets, head restraints and 6-way power driver's seat
- Premium cloth 60/40 split rear seat
- Convenience Group including speed control, perimeter alarm and front and rear floor mats

PERFORMANCE/HANDLING

Includes all the features of Escape XLS plus the following additions or upgrades:

- Duratec 30 - 3.0L DOHC V-6 engine (XLT Sport)
- **Duratec 23 - 2.3L I-4 engine (XLT)**
- 4-speed automatic transmission
- P235/70R16 BSW (FWD)/OWL (4WD) all-season tires (XLT)
- P235/70R16 OWL all-season tires (XLT Sport)

DESIGN/STYLING

Includes all the features of Escape XLS plus the following additions or upgrades:

- 16-inch 5-spoke cast aluminum wheels (XLT)
- 16-inch 5-spoke bright machined aluminum wheels (XLT Sport)
- A-Gloss Dark Shadow Grey fascias, bodyside claddings, bumpers and wheelip moldings (XLT Sport)
- Roof rack with adjustable crossbars
- Fog lamps
- Black step bars (XLT Sport)

SAFETY/SECURITY

Includes all the features of Escape XLS plus the following upgrade:

- Privacy glass
- **Perimeter alarm**

QUALITY/RELIABILITY/DURABILITY

Key features are the same as Escape XLS.

Escape Limited



COMFORT/CONVENIENCE

Includes all the features of Escape XLT plus the following additions or upgrades:

- Sun visors with dual illuminated vanity mirrors
- Premium leather-trimmed low-back bucket seats with driver and passenger map pockets, head restraints and 6-way power driver's seat
- Premium leather-trimmed 60/40 split rear seat
- Deluxe overhead console with dual storage bins⁽¹⁾
- Auto-dimming rearview mirror
- Automatic headlamps
- Message center
- Leather-wrapped steering wheel

PERFORMANCE/HANDLING

Includes all the features of Escape XLT plus the following upgrade:

- P235/70R16 BSW all-season tires

DESIGN/STYLING

Includes all the features of Escape XLT plus the following additions or upgrades:

- Monochromatic appearance — including A-Gloss body-color bumpers, bodyside cladding, door handles and liftgate molding
- 16-inch 5-spoke bright machined aluminum wheels

SAFETY/SECURITY

Key features are the same as Escape XLT.

QUALITY/RELIABILITY/DURABILITY

Key features are the same as Escape XLS.

(1) Not available with optional moonroof (43M).

COMFORT/CONVENIENCE

This page is about:

- 5-passenger Seating
- 60/40 Split Rear Seat
- Reclining Front Seats
- Center Rear Head Restraint
- Message Center
- Large Interior Volume

2005 Escape

Comfort/Convenience

Key Features

It isn't one thing about the Escape interior that stands out. It's all the little things — like Escape's flexible cargo area and seating versatility, which make it very user-friendly. So present the whole package, emphasizing those things that meet the lifestyle needs of your particular customer. There are a lot of them. Just look around.



5-passenger Seating — with an adjustable rear seat for greater comfort and storage flexibility

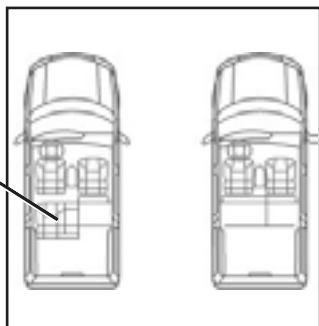

60/40 Split Rear Seat — includes fold-flat feature and removable seat cushion for passenger- and cargo-carrying flexibility

Reclining Front Seats — dual reclining front seats for driver and passenger help keep occupants comfortable



Center Rear Head Restraint — provides additional comfort and safety for the center rear-seat passenger

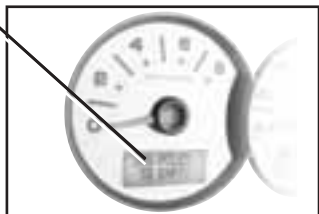

Message Center — with oil-change reminder, average fuel economy and warning lights, including low fuel, 4WD system status and lamp-out indicator (standard on Limited)



Large Interior Volume — 128.4 cubic feet of interior space providing plenty of space for passengers and cargo

6-disc in-dash CD player — offers convenient loading for up to 6 CDs (standard XLT and above)

Climate Control System — high fan motor output produces excellent airflow volume for passenger comfort



Cabin Air Filter — traps pollen and dust particles — over 90 percent of all particulates larger than 3 microns (dealer-installed option)

Instrument Panel — features easy-to-read warm steel-color frames and white-faced gauges. Includes message center on Limited



Cargo Convenience Group — rear cargo storage bin and retractable cargo cover provide added safety, security and cargo-carrying capacity.

LEARNING PATH

| To learn more about: | You will find more info here: |
|----------------------|-------------------------------|
| Audio Choices | Audio section — pg. 18 |

2005 Escape

Comfort/Convenience

COMFORT/CONVENIENCE

This page is about:

- Storage Benefits
- Tilt Steering Column
- Instrument Panel Design
- Cargo Area
- Interior Volume
- 60/40 Split Rear Seat

Escape Comfort/Convenience Specifics

1 Escape's interior **storage benefits** are carefully thought out. The Escape team actually "spied" on people in parking lots to see how they used the cargo areas of their vehicles — especially those driving competitive models in the small SUV segment. The team noticed people trying to fit everything from surfboards to big-screen televisions into vehicles that weren't equipped to handle a variety of items. Then they went to work to create a vehicle that could.



2 Escape's **tilt steering column** is standard — some make this an optional feature. During the development phase, one of the Escape engineers was pregnant. She started paying particular attention to vehicle elements that could become a hindrance to her. The whole design team saw the benefit of a feature (like tilt steering) that anticipated the changing needs of young owners. Not only that, they made it standard.

3 When developing the **instrument panel design**, engineers tested the white background at various times of the day and in all lighting conditions. The result? Black accent lines and green lights were incorporated to improve readability at dusk and other low-light conditions.



Escape Interior Specifics

Cargo Area

- 29.3 cubic feet of cargo capacity (rear seat up), 66.3 cubic feet (rear seat down and rear seat cushion removed)
- Flat loadfloor contributes to maximized cargo-carrying versatility
- Removable rear seat cushion
- 4 cargo hooks
- Cargo Convenience Group (optional)
- **Coat hook**

Interior Volume

- 128.4 cubic feet total volume
- Surprisingly spacious, with 5-passenger seating
- Cargo storage bin provides nearly 1.5 cu. ft. of additional space (part of Cargo Convenience Group)

60/40 Split Rear Seat

- Enhances interior versatility
- Allows flexibility for passengers and cargo
- Easy to operate
- Unique center head restraint
- 3-point lap/shoulder safety belt in rear center position
- Available on all series



Presentation Tip

Ask your customers about their recreational activities. Whether they enjoy camping or woodworking or anything else, show them how Escape can handle some of the typical supplies they might need to put in their vehicle. Consider having real props on hand to make it even more memorable. Demonstrate how the rear seat folds flat and how the seat cushion can even be removed. All this makes Escape the kind of SUV that transcends typical size-based parameters and, instead, offers smartly designed solutions.

This page is about:

- Speed Control
- Overhead Consoles
- Storage
- Flow-through Floor Console
- Power Features
- Comfort/Convenience Specifics

2005 Escape

Comfort/Convenience

Additional Features

Speed Control

- Tap-up/tap-down feature
- Increase/decrease speed in 1-mph increments



Overhead Consoles

- Dual storage bins for sunglasses/garage door opener
- Moonroof mini console includes storage bin and map lights



Storage

- Storage space in the front doors, instrument panel and cargo area provides room for small items



Flow-through Floor Console

- Cup holders are larger and deeper with removable inserts to accommodate a larger variety of sizes
- Includes an additional front storage bin and 12-volt auxiliary power point
- A floor gearshift is now included with the automatic transmission



Power Features

- All Escape models have power windows, locks, mirrors and Remote Keyless Entry System
- Front driver and passenger window and lock switches are backlit for easy operation



Escape Comfort/Convenience Specifics

Escape is loaded with convenience features that many customers will associate with higher-priced vehicles. Besides the features called out above, consider these:

- **Accessory Delay Feature** — allows occupants to use the stereo, power windows and power moonroof after the ignition is turned off and before a door is opened. It provides power for up to 10 minutes
- **Auto Headlamp Off** — turns the headlamps off after a fixed time in order to conserve battery power

- **Smoker's Package** — features an ashcup and cigarette lighter that can be mounted to the center console. The Smoker's Package is available as a dealer-installed accessory

Luxury Comfort Package (available on Limited)

- **MACH® 300 Audio system with premium AM/FM stereo/6-disc in-dash CD player with 7 speakers and automatic volume control**
- **Heated driver and front passenger seats**
- **Heated sideview mirrors**
- **Reverse Sensing System**

Presentation Tip

Point out the Speed Control feature to customers — it enables them to adjust their speed as conditions warrant without having to turn the speed control system off and then back on.

2005 Escape

Comfort/Convenience

COMFORT/CONVENIENCE

This page is about:

- Assist Handles
- Cargo Convenience Group
- Safety Belt D-rings
- Removable Rear Seat Cushions
- Cargo Floor Hooks
- Seating and Audio Specifics

Additional Features

| Feature | Benefit |
|--------------------------------------|---|
| Assist Handles | Two front and two rear assist handles for easy entry and exit (rear assist handles not available with optional Safety Canopy™ System) |
| Cargo Convenience Group | Includes a retractable cargo area cover and rear cargo storage bin located beneath the rear cargo loadfloor providing added safety, security and cargo-carrying capability (optional on all models) |
| Front Adjustable Safety Belt D-rings | Provide safety belt comfort for various size occupants |
| Removable Rear Seat Cushions | Added cargo-carrying flexibility |
| Cargo Floor Hooks (4) | Provide tie-down points to help secure cargo |



Escape Seating and Audio Specifics

Seating Choices

- **XLS Manual, XLS** — manual cloth low-back dual reclining bucket seats with adjustable head restraints and cloth 60/40 split rear seat
- **XLT, XLT Sport** — low-back dual reclining bucket seats with premium cloth and adjustable head restraints, seatback map pockets and 6-way power driver's seat. Premium cloth 60/40 split rear seat (**leather seating available**)
- **Limited** — premium leather-trimmed low-back dual reclining bucket seats with adjustable head restraints, seatback map pockets and 6-way power driver's seat. Premium leather-trimmed 60/40 split rear seat



Audio System Choices

- **XLS Manual, XLS** — standard premium AM/FM stereo/single-disc CD player, 60 watts of power, 4 premium speakers, digital clock, full electronic tuning with Seek
- **XLT, XLT Sport and Limited** — standard premium AM/FM stereo/6-disc in-dash CD player, 80 watts of power, Radio Data System (RDS), digital clock, full electronic tuning with Seek, 4 premium speakers
- **XLT, XLT Sport** — optional premium AM/FM stereo/cassette/single-disc CD player, 80 watts of power, 4 premium speakers, digital clock, full electronic tuning with Seek
- **XLT, XLT Sport and Limited** — optional MACH® 300 Audio System with premium AM/FM stereo/6-disc in-dash CD player, 320 watts of power, 90-watt woofer output channel, equalized output, Radio Data System (RDS), digital clock, full electronic tuning with Seek, 7 speakers including subwoofer and 2 tweeters. Includes Sirius satellite radio capability. Also part of optional Luxury Comfort Package on Limited
 - Includes Automatic Volume Control when ordered as part of Limited Luxury Comfort Package

2005 Escape

Performance/Handling

This page is about:

- Intelligent 4WD System
- Powertrain Combinations
- Engines
- Four-valve Technology
- "Green" Vehicle Features

Key Features

Intelligent 4WD (Replaces Control Trac® II) System

Escape is in the small SUV segment and, along with Escape Hybrid, is the only Ford SUV with front-wheel drive, but it has plenty of big ideas when it comes to performance. Foremost among them is the Intelligent 4WD System, which automatically distributes power to the wheels with the most traction.

How It Works

- The system always drives the front wheels and monitors vehicle and driving surface conditions using signals such as individual wheel speeds and throttle position
- The system seamlessly sends power to the rear wheels as needed to control wheel slip or to prevent it from occurring in the first place

Customer Benefits

- Does not require a driver-operated switch
- Improved traction by automatically delivering torque to the wheels with the most traction
- Improved vehicle stability by reacting quickly to changes in road conditions
- Improved fuel economy
- Allows for the cost and weight advantage of offering a mini-spare tire by detecting the spare tire and adjusting the torque split between front and rear wheels accordingly



Powertrain Combinations

| Powertrain (Engine/Transmission) | Horsepower (SAE net @ rpm) | Torque (lb.-ft. @ rpm) |
|---|----------------------------|------------------------|
| Duratec 23 - 2.3L I-4 5-speed Manual; 4-speed Automatic Overdrive | 153 @ 5800 | 152 @ 4250 |
| Duratec 30 - 3.0L DOHC V-6 4-speed Automatic Overdrive | 200 @ 6000 | 193 @ 4850 |

Powertrain Specifics

Duratec 23 - 2.3L I-4 Engine

- Provides **20 percent** more horsepower (153 hp) and torque (152 lb.-ft.) than the 2.0L it replaces
- Noise, vibration and harshness (NVH) are reduced
- Shift quality is improved
- Meets LEV II emissions standards
- Mated to the 4-speed automatic transmission on XLS (except XLS Manual) and XLT
- Mated to 5-speed manual transmission (XLS Manual)

Duratec 30 - 3.0L DOHC V-6 Engine

- Improved automatic shift quality provides quicker and smoother upshifts
- Provides more power than most overhead valve engines of comparable size
- Delivers excellent fuel economy for a vehicle in this class
- 200 horsepower @ 6000 rpm

Four-valve Technology

- Both engines use two intake and two exhaust valves per cylinder
- This design improves the flow of the air/fuel mixture into the engine and the flow of exhaust gas out of the engine, resulting in increased horsepower and torque compared to overhead valve engines of similar size

"Green" Vehicle Features

- Both the Duratec 23 - 2.3L I-4 and the Duratec 30 - 3.0L V-6 engines meet LEV II emissions standards
- Both engines use an electrical vapor management system that reduces evaporation of fuel into the air
- Both engines feature a new catalytic converter that requires less precious metal and helps reduce emissions
- Both engines deliver excellent fuel economy

Escape

LEARNING PATH

| To learn more about: | You will find more info here: |
|----------------------|-------------------------------|
| Intelligent 4WD | Escape Launch Video |
| Off-Road Capability | Escape Launch Video |

| Powertrain | City/Hwy. (mpg) |
|--|-----------------|
| Front-wheel Drive | |
| Duratec 23 - 2.3L I-4 with 5-speed manual | 24/29 |
| Duratec 23 - 2.3L I-4 with 4-speed automatic | 22/25 |
| Duratec 30 - 3.0L V-6 with 4-speed automatic | 20/25 |
| Four-wheel Drive | |
| Duratec 23 - 2.3L I-4 with 5-speed manual | 22/26 |
| Duratec 23 - 2.3L I-4 with 4-speed automatic | 19/22 |
| Duratec 30 - 3.0L V-6 with 4-speed automatic | 18/22 |

2005 Escape

Performance/Handling

PERFORMANCE/HANDLING

This page is about:

- Four-wheel Independent Suspension
- Front and Rear Suspensions
- Towing Capacity
- Rack-and-pinion Steering
- Tires
- Wheels

A Closer Look: The Ride

Four-wheel Independent Suspension

- Optimizes handling and steering feel for excellent vehicle tracking and stability when braking
- Each wheel absorbs bumps independently
- Nimble handling and maneuverability when combined with its powerful engine

Front Suspension

- For 2005, larger diameter front struts and modified lower control arm bushings help isolate shock force for improved ride and comfort
- Precise steering is improved due to low-friction stabilizer bar links
- A redesigned stabilizer bar helps reduce body lean in turns and contributes to improved handling

Rear Suspension

- Double lateral link and semi-trailing arm design
- Long travel jounce bumpers to help absorb harsh impacts
- Allows lower spring rates for a smooth ride



Additional Features

| Feature | Benefit |
|---|--|
| Front-wheel Drive | The only Ford SUV (along with Escape Hybrid) with front-wheel drive. Driving force applied through front wheels; excellent handling, traction and control |
| Towing Capacity | Adds to Escape's versatility (1500-lb. maximum with Duratec 23 - 2.3L I-4; 3500-lb. maximum with Duratec 30 - 3.0L V-6 and optional Class II Trailer Towing Package) |
| Compact Spare Wheel and Tire ⁽¹⁾ | Underbody mounted — doesn't interfere with cargo space or rear-window visibility |
| Rack-and-pinion Steering | Tight, responsive steering with low steering effort |

Escape Performance/Handling Specifics

Tires

- P225/75R15 BSW all-season tires (standard on XLS) — provide confident traction and handling in a variety of weather conditions
- P235/70R16 BSW all-season tires (standard on XLT FWD and Limited) — offer a wider stance
- P235/70R16 OWL all-season tires (standard on XLT 4WD, XLS Blast and XLT Sport; optional on XLT FWD)
- P235/70R16 OWL all-terrain tires (XLT No Boundaries™ Package) — provide traction for off-road surfaces

Wheels

- 15 x 6.5-inch 5-spoke styled steel wheels (standard on XLS)
- 15 x 6.5-inch 5-spoke cast aluminum wheels (optional on XLS)
- 16 x 7-inch 5-spoke painted grey aluminum wheels (XLS Blast)
- 16 x 7-inch 5-spoke cast aluminum wheels (standard on XLT)
- 16 x 7-inch 5-spoke painted cast aluminum wheels (XLT No Boundaries™ Package)
- 16 x 7-inch 5-spoke bright machined cast aluminum wheels (standard on XLT Sport and Limited)

Fuel Tank

- 16.5-gallon capacity

(1) Non-matching, temporary full-size spare tire and wheel optional on XLT, XLT Sport and Limited models.

DESIGN/STYLING

This page is about:

- Unibody Monocoque Construction
- Exterior Styling
- No Boundaries™ Rack System
- **New Front and Rear Fascias**
- **Roomy, Comfortable Interior**
- Black Step Bars

2005 Escape

Design/Styling

Key Features

The 2005 Escape fits nicely into the Ford lineup:

- It's not derived from a minivan or a car, or even a compact pickup truck, although many of its competitors are. For more on the design and styling features that make Escape unique, read on

- Escape is a sport utility vehicle that's small in stature but big in style, fun and capability

Unibody Monocoque Construction — lightweight and compact design that uses the body for structural stability

Exterior Styling — freshened exterior styling cues include round fog lamps (XLT, XLT Sport and Limited), front and rear fascias, clear lens headlamps, new 15-inch aluminum wheels for XLS (optional) and new 16-inch aluminum wheels for XLT

No Boundaries™ Rack System — maximizes Escape's carrying capability with a unique system **that allows 100 lbs. to be carried on top and 100 lbs. on the rear liftgate of vehicle** (included in XLT No Boundaries Package)

New Front and Rear Fascias — reinforce Escape's rugged-yet-refined design theme



Roomy, Comfortable Interior — **Escape provides comfortable seating for up to 5 with a full 100 cu. ft. of passenger space. (Available leather-trimmed interior shown)**

Black Step Bars — contribute to appearance while providing a practical benefit that makes getting into and out of Escape easier. Optional on XLS, XLT; standard on XLT with No Boundaries Package and XLT Sport

Flip-up Rear Glass and Liftgate — provide two ways to access the cargo compartment, depending on the customer's immediate needs



2005 Escape

Design/Styling

DESIGN/STYLING

This page is about:

- XLT No Boundaries™ Package —
- No Boundaries Rack System —
- Body Structure —
- Black Step Bars —
- Additional Features** —
- Exterior/Interior Colors —

Escape Design/Styling Specifics

XLT No Boundaries™ Package

- No Boundaries Rack System
- Class II Trailer Towing Package
- 16-inch painted aluminum wheels
- P235/70R16 all-terrain OWL tires
- Wheelip moldings
- Black step bars
- New unique cloth fabric
- New molded-in-color silver-finish front and rear appearance skid plates

No Boundaries Rack System

- Can be used as a standard rack or pulled down over the back
- Unlock from the roof position, pull it out and rotate it down
- Allows Escape to accommodate 100 lbs. of cargo on the roof and on the back of the vehicle
- Included **only** in XLT No Boundaries Package

Body Structure

- Unibody monocoque design where the body structure and the frame are unitized to help maximize interior space
- Unibody creates a structural “cage” surrounding the passenger compartment
- The front-end structure directs crash energy away from occupants and into the vehicle structure
- Interior space is enhanced through the use of independent rear suspension

Black Step Bars

- Provide added ease of entry and exit
- Contribute to rugged-yet-refined styling
- Optional on XLS, XLT; standard on XLT with No Boundaries Package and XLT Sport

Additional Features

| Feature | Benefit |
|---------------------------------|--|
| Molded-in Exterior Trim | Improves appearance with rugged, off-road ready appearance |
| Front and Rear Bumpers | Reinforce athletic profile; integrated front brush guards provide added vehicle protection; step-surface on rear bumper adds to customer convenience |
| Flip-up Rear Glass and Liftgate | Increase Escape’s functionality and convenience by offering two ways for customers to access the cargo area — through the flip-up glass for small items, or through the entire liftgate area for bulky items |

Escape Design/Styling Specifics

Exterior Colors

- Oxford White Clearcoat
- Silver Metallic Clearcoat
- Sonic Blue Clearcoat Metallic
- Dark Shadow Grey Clearcoat Metallic
- Black Clearcoat

- Red Fire Clearcoat Metallic
- Gold Ash Clearcoat Metallic
- Norseia Blue Clearcoat Metallic
- Titanium Green Clearcoat Metallic
- Blazing Copper Clearcoat Metallic (XLS Blast Package only)

Interior Colors

- Medium/Dark Flint
- Medium/Dark Pebble
- Ebony Black

2005 Escape

Safety/Security

This page is about:

- Lower Anchors and Tethers for Children
- SecuriLock® Passive Anti-theft System
- Unibody Monocoque Construction
- Side Door Intrusion Beams
- Remote Keyless Entry System
- New Personal Safety System™

Key Features

Lower Anchors and Tethers for Children (LATCH) — help to secure a child safety seat. Tether straps are provided by child safety seat manufacturer

SecuriLock® Passive Anti-theft System — designed to help prevent the engine from being started unless a coded key programmed to your vehicle is used

Unibody Monocoque Construction with Crumple Zones — integrates the frame and body into one structure for reduced weight and optimum passenger space

Side Door Intrusion Beams — steel beams in the side doors add structural stability, absorb energy and help reduce passenger compartment intrusion in certain side impacts

Remote Keyless Entry System — provides an added level of convenience and security for Escape customers

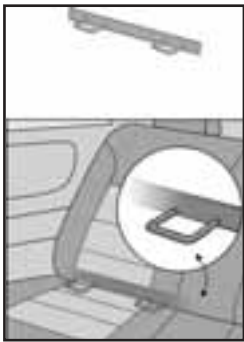

Power Four-wheel Disc Brakes — resist brake fade and improve stopping distance in hard-braking situations. Standard on all V-6 4WD models



New Personal Safety System™ — includes new dual-stage driver and front passenger airbags and the new **Front Passenger Sensing System (FPSS)** for the front passenger seat to help protect front-seat occupants during a front-end collision

Safety Package — includes Safety Canopy™ System, providing side-impact head and rollover protection for front- and second-row outboard passengers and front-side airbags, providing additional protection for the head and chest of front outboard occupants during certain side-impact collisions

Four-wheel Anti-lock Braking System (ABS) — provides consistent stopping power, and excellent braking and steering control — even under hard-braking conditions. For 2005, ABS is standard on all models

Electronic Brake Force Distribution (EBD) — registers slip between the front and rear axle wheel speeds and controls the brake pressure levels accordingly to optimize brake performance under all driving conditions

Escape Safety/Security Specifics

Remote Keyless Entry System

- User can choose to lock or unlock driver's door only or all doors
- Transmitter has a Panic button; when pressed from up to 33 feet from vehicle, horn sounds and headlamps flash

SecuriLock Passive Anti-theft System

- System is designed to help prevent the engine from being started unless a coded key programmed to the vehicle is used
- Uses specially coded key with 72 quadrillion possible codes to start vehicle
- System arms automatically when key is removed from ignition
- System disarms when the correctly coded key is reinserted into the ignition

Belt-Minder™ System

- Reminds driver and front passenger to buckle up because the safety belt is the most important safety feature in the vehicle
- If driver or front passenger is unbuckled and the vehicle has reached a speed over 3 mph, the system sounds a chime and flashes a warning light on the instrument cluster

Theater Lighting

- Provides added convenience and security
- Brightly illuminates interior whenever door is opened
- When all doors are closed, the lights gradually dim

A Closer Look:

Share this info with customers who want to know more:

No Narrow Escape

Many in the industry doubted Escape's ability to achieve a high safety rating due to just 18 inches of crush space in the vehicle's design. The crush space is located between the front of the instrument panel and the back of the front bumper. It refers to how much space is available for the vehicle to absorb crash energy. With just 18 inches of crush space, a high safety rating was thought to be unattainable. Escape's front crash structure (specifically the front aprons) absorbs crash energy and helps pull it away from the front of the vehicle and away from the cabin. This design enhances the ability of the crush space to absorb crash energy.

2005 Escape

Safety/Security

SAFETY/SECURITY

This page is about:

- Dual-stage Front Airbags
- Front Passenger Sensing System (FPSS)
- Safety Package
- "Safety Cell" Construction
- Safety Belts

Escape Protection Specifics

Personal Safety System™

Dual-stage Driver and Right Front Passenger Airbag Supplemental Restraint System (SRS)

- Provides the capability of deploying in the full-powered mode or with less pressure in the Stage 1 mode
- Multipoint crash-sensing system includes the Restraint Control Module plus satellite sensors on the front radiator support for frontal crashes and on the B- and C-pillars for side impacts. The sensors help to determine crash severity early in a collision so that the appropriate airbag inflation pressure can be determined
- Driver's-seat position sensor monitors how close the driver's seat is in relation to the steering wheel — another factor in determining the airbag inflation pressure

Front Passenger Sensing System (FPSS)

- The front passenger seat includes the **Front Passenger Sensing System (FPSS)** to control airbag deployment
- The passenger-seat weight sensor turns the passenger airbag off if a small-statured person is in the seat or if it is empty

Safety Package

- Includes the Safety Canopy™ System which provides enhanced side-impact head protection and rollover protection for first- and second-row outboard occupants by deploying from the headliner in certain types of accidents
- A sensor monitors the vehicle's roll angle and roll rate. If the system determines that a rollover may be imminent, the Safety Canopy deploys and can remain inflated for several seconds

- The Safety Canopy can also be triggered in certain side impacts
- Also includes dual front side airbags that are mounted to the front seats and "move" with the occupant to provide better protection than side airbags that deploy from the door. These airbags provide added protection to front outboard occupant's head and chest during certain side-impact collisions

"Safety Cell" Construction

- Helps absorb impact energy before it reaches vehicle occupants
- Front-end structure with reinforced subframe to absorb energy
- Cross-vehicle beam provides additional mounting point for steering column and airbag
- Includes high-strength steel side intrusion door beams

Safety Belts

- Use latest technology to provide occupant protection
- Feature manual 3-point system in all seating positions including the rear center seat
- Front-seat safety belt pretensioners automatically tighten to more effectively restrain front outboard occupants in the event of certain frontal collisions
- Front-seat energy management retractors gradually allow the safety belts to loosen if necessary — reducing the force of the belts on the occupant's chest and allowing them to move forward very slightly and into the airbags
- Front shoulder belt D-ring height adjuster for comfort

Additional Features

| Feature | Benefit |
|----------------------------------|---|
| Illuminated Entry System | Illuminates Escape's interior when any door is opened for convenience and security |
| Rear-door Child Safety Locks | Prevent children from opening a door from inside |
| Battery Saver | Helps prevent battery power drainage by automatically turning off interior and cargo lights 40 minutes after the last door is closed and the ignition key remains off |
| Fuel Pump Inertia Shutoff Switch | Prevents fuel from being pumped to the engine in the event of a collision |
| Seat Design | Low-back seats with adjustable head restraints in all seating positions to help provide whiplash protection |

QUALITY/RELIABILITY/DURABILITY

This page is about:

- 100,000-mile Scheduled Tune-up Interval
- New Vehicle Limited Warranty
- Corrosion Protection
- Electronic Engine Controls (EEC-V)
- Interior Quietness

2005 Escape

Quality/Reliability/Durability

Key Features

Escape has undergone the rigors of worldwide testing. Its components are designed to deliver reliable performance with long-life durability.

100,000-mile Scheduled

Tune-up Interval — engine is designed to run for 100,000 miles before its first tune-up⁽¹⁾

New Vehicle Limited Warranty — offers bumper-to-bumper coverage; no deductible

Corrosion Protection — two-sided galvanized steel provides outstanding corrosion resistance

Electronic Engine Controls (EEC-V) — helps engine deliver optimum efficiency, performance and emissions control

Interior Quietness — an improved sound package at the dash and body panels includes additional door seals for less noise, vibration and harshness (NVH). Sound-insulating material is used extensively throughout the interior trim and carpet. Additionally, quieter tires and a retuned suspension add to resulting levels of wind and road noise that are among the lowest in the small SUV segment



A Closer Look:

Share this info with customers who want to know more:

Worldwide Testing Helps Ensure Quality, Reliability and Durability

Escape has undergone rigorous testing in locations worldwide to examine specific aspects of the vehicle. "We tested brakes in the Grossglockner Mountains of the Swiss Alps and in Mexico," reports one Escape engineer. "There's a three-and-a-half-mile descent from Mexico City to Puerto Vallarta that requires almost constant brake use to stay on the road. We gave a few Escape SUVs to Las Vegas taxi companies. They're notoriously tough on transmissions and it gave us a good insight into Escape's durability. The Royal Canadian Mounted Police and the Denver Police Department also tested Escape in their high-altitude, high-demand environments."

LEARNING PATH

| To learn more about: | You will find more info here: |
|---------------------------|-------------------------------|
| Durability in Performance | Escape Launch Video |

2005 Escape

Quality/Reliability/Durability

QUALITY/RELIABILITY/DURABILITY

This page is about:

- Serviceability
- Corrosion Protection
- 100,000-mile Scheduled Tune-up Interval
- New Vehicle Limited Warranty
- EEC-V/OBD II
- Roadside Assistance

A Closer Look: Serviceability



- Well-designed engine bay with easy access to key components
- Frequently serviced points are coded in bright yellow or identified with lettering for easy identification
- See-through fluid reservoirs
- Extended lifetime service intervals for automatic transmission, and for rear-wheel power takeoff and rear differential (4WD models)
- Sectioned exhaust system for easy replacement, if necessary

Additional Features

| Feature | Benefit |
|---|---|
| Corrosion Protection | Major body panels of two-sided galvanized steel, wax spray applied to door inners and special chip-resistant primer applied on hood |
| 100,000-mile Scheduled Tune-up Interval | Under normal driving conditions with regular fluid and filter changes, engine is designed to run up to 100,000 miles before its first tune-up |
| New Vehicle Limited Warranty | 3-year/36,000-mile bumper-to-bumper coverage with no deductible and 5-year/unlimited-mileage Corrosion Perforation coverage ⁽¹⁾ |
| Electronic Engine Controls (EEC-V) | Ensures optimum engine efficiency, performance and emissions control; on-board diagnostics system (OBD II) enables service technicians to quickly and efficiently trace serviceability/maintenance problems |

Escape Quality/Reliability/Durability Specifics

Roadside Assistance

The Roadside Assistance program is available during the 3-year/36,000-mile limited warranty period. It offers a number of features that include:

- Toll-free number operational 24 hours a day, every day — 1-800-241-FORD

Customers who call the toll-free number can request services to change a flat tire, jump-start a battery, unlock the vehicle, deliver fuel or tow the vehicle to the nearest Ford Motor Company dealership or the selling dealership if within 35 miles.

(1) 5-year/50,000-mile Safety Restraint coverage.

AUDIO

This page is about:

- Premium AM/FM Stereo/Single-disc CD Player
- Premium AM/FM Stereo/Cassette/Single-disc CD Player
- Premium AM/FM Stereo/6-disc In-dash CD Player
- MACH® 300 Audio System with Premium AM/FM Stereo/6-disc In-dash CD Player
- Sirius Satellite Radio

2005 Escape

Audio⁽¹⁾

Premium AM/FM Stereo/Single-disc CD Player⁽²⁾

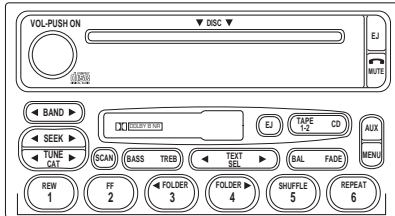

(Standard on XLS Manual and XLS)

- 60 watts of power (RMS)
- 4 speakers
- Automatic disc storage

Premium AM/FM Stereo/Cassette/Single-disc CD Player⁽²⁾

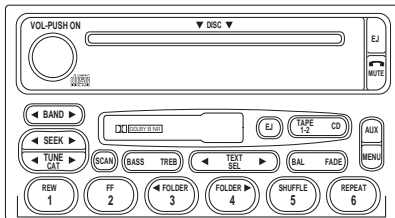

(Optional on XLT and XLT Sport)

- 80 watts
- 4 speakers
- Electronic logic cassette tape player with soft-touch controls
- Radio play during rewind/fast forward
- Automatic disc storage

Premium AM/FM Stereo/6-disc In-dash CD Player⁽²⁾

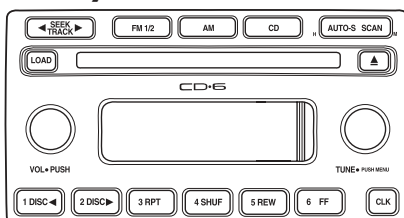

(Standard on XLT, XLT Sport and Limited)

- 80 watts
- 4 speakers
- RDS (Radio Data System) function
- Random shuffle across all CDs
- 3-second memory buffer
- Selective eject/load capability

MACH® 300 Audio System with Premium AM/FM Stereo/6-disc In-dash CD Player⁽²⁾

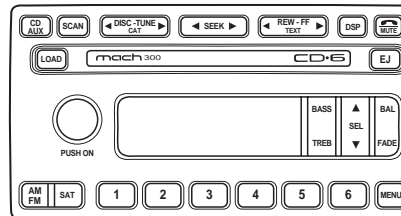

(Optional on XLT, XLT Sport and Limited)

- 320 watts
- 7 speakers, including subwoofer and 2 tweeters
- RDS (Radio Data System) function
- Random shuffle across all CDs
- Selective eject/load capability
- Automatic volume control (Limited Luxury Comfort Package only)
- Sirius satellite radio capability

More About the Sirius Satellite Radio

- Sirius satellite radio-ready with Satellite button (SAT) to activate the system, Text button (TEXT) to provide information about the artist and song title, and Category button (CAT) to scroll through a variety of format types
- Key benefits of Sirius satellite radio include:
 - 100 percent commercial-free music
 - Seamless coverage anywhere in the contiguous U.S. (system not equipped to operate in Alaska or Hawaii)
 - Over 60 streams (channels) of original pop, rock, country, hip-hop, R&B, dance, jazz/standards and classical music
 - Over 50 streams (channels) of sports, news and entertainment programming
 - Unlike conventional radio, DJs talk about the music, not over it
 - Artist and title information keeps customers informed about who they're listening to
- Requires dealer-installed kit to activate service, which consists of antenna, Down Link Processor (DLP) and wire harness. Once the hardware is in place, the owner can apply for the Sirius satellite radio subscription service for a monthly fee
- Installation of the kit can be done through Visteon distribution centers — or dealerships have the option of installing the kits in-house. For more details on installation, please contact Visteon at (800) 367-3333
- More information on the service is available online at www.sirius.com or toll-free at (888) 539-SIRIUS (7474)

(1) Refer to the latest Dealer Ordering Guide for specific audio availability.







(2) Refer to the Owner's Guide for radio operating instructions.

2005 Escape Wheels

WHEELS

This page is about:

- 15" Styled-steel
- 15" Aluminum
- 16" Painted Grey Aluminum
- 16" Aluminum
- 16" Painted Aluminum
- 16" Bright Machined Aluminum

| Wheel | | XLS Manual | XLS | XLT | XLT Sport | Limited |
|------------------------------------|---|------------------------------------|--|---|---|------------------------------------|
| 15" Styled-steel Wheel |  | Standard on Order Codes 100A, 200A | Standard on Order Codes 120A, 220A | — | — | — |
| 15" Aluminum Wheel |  | Optional on Order Codes 100A, 200A | Optional on Order Codes 120A, 220A | — | — | — |
| 16" Painted Grey Aluminum Wheel |  | — | Included on XLS Blast Package (47M) Order Codes 120A, 220A | — | — | — |
| 16" Aluminum Wheel |  | — | — | Standard on Order Codes 305A, 310A, 405A, 400B | — | — |
| 16" Painted Aluminum Wheel |  | — | — | Included with XLT No Boundaries™ Package (47S) Optional on Fleet – 4WD only ⁽¹⁾ | Optional on Fleet – 4WD only ⁽¹⁾ | — |
| 16" Bright Machined Aluminum Wheel |  | — | — | — | Standard on Order Codes 330A, 410A | Standard on Order Codes 500A, 600A |

— = Not available

(1) Requires P235/70R16 all-terrain OWL tire.

NOTE: Please refer to the 2005 Dealer Ordering Guide for wheel availability.

2005 Escape

Seats/Instrument Cluster

This page is about:

- Seats
- Instrument Cluster

Seats

| Interior Trim Type and Color Selector NOTE: First character denotes type, second character denotes color. | Interior Colors | | |
|--|--------------------------|---------------------------|----------------|
| | Medium/ Dark Flint | Medium/ Dark Pebble | Ebony Black |
| XLS Manual/XLS Cloth Bucket Seats with 60/40 Split Rear Seat | W2 | WH | |
| XLT/XLT Sport Premium Cloth Bucket Seats with 60/40 Split Rear Seat Leather-trimmed Bucket Seats with 60/40 Split Rear Seat | A2 N2 | AH NH | |
| XLT No Boundaries™ Package Unique Premium Cloth Bucket Seats with 60/40 Split Rear Seat Leather-trimmed Bucket Seats with 60/40 Split Rear Seat | B2 N2 | BH NH | |
| Limited Premium Leather-trimmed Bucket Seats with 60/40 Split Rear Seat | | CH | CB |

NOTE: Please refer to the 2005 Color and Upholstery Book or the Specifications section of **eSourceBook** (esourcebook.dealerconnection.com) for illustrations of the available seating choices.

Instrument Cluster

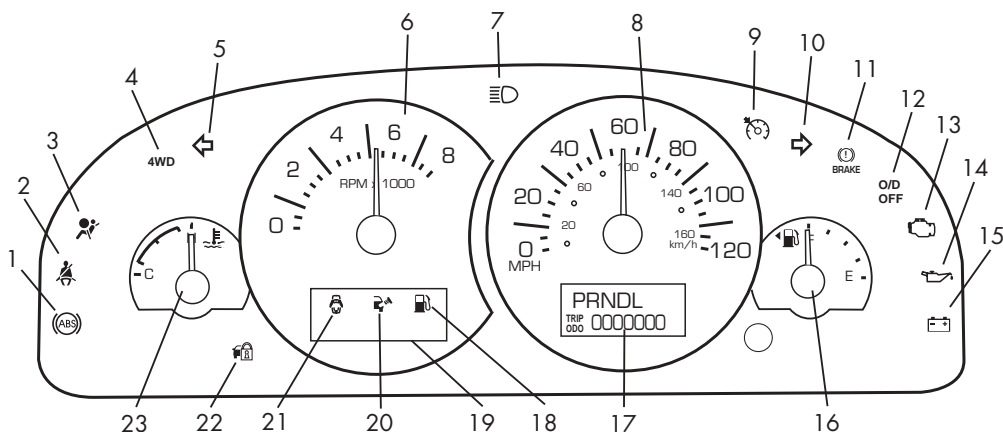

- | | | |
|---|--|---|
| 1. Anti-lock Braking System indicator/warning light | 8. Speedometer | 17. Automatic transmission gearshift indicator ⁽¹⁾ /odometer/trip odometer |
| 2. Fasten safety belt indicator/warning light | 9. Speed control indicator ⁽¹⁾ | 18. Low fuel indicator |
| 3. Airbag readiness indicator/warning light | 10. Turn signal indicator | 19. Message Center area on Limited |
| 4. Four-wheel Drive (4WD) system indicator ⁽¹⁾ | 11. Brake system warning light/parking brake indicator | 20. Loose fuel cap warning light |
| 5. Turn signal indicator | 12. Overdrive off indicator | 21. Door ajar indicator |
| 6. Tachometer | 13. Check engine warning light | 22. Anti-theft light indicator |
| 7. High-beam indicator | 14. Oil pressure indicator | 23. Engine coolant temperature gauge |
| | 15. Battery voltage indicator | |
| | 16. Fuel gauge | |

(1) If equipped.

2005 Escape

GVWR, Towing and Powertrains

GVWR, TOWING AND POWERTRAINS

This page is about:

- Maximum GVWR
- Trailer Towing Applications
- Special Applications

Maximum GVWR

| Series | Maximum GVWR (lbs.) ⁽¹⁾ |
|---------------------------------|------------------------------------|
| Duratec 23 - 2.3L FWD Manual | 4300 |
| Duratec 23 - 2.3L 4WD Manual | 4460 |
| Duratec 23 - 2.3L FWD Automatic | 4360 |
| Duratec 23 - 2.3L 4WD Automatic | 4520 |
| Duratec 30 - 3.0L FWD Automatic | 4500 |
| Duratec 30 - 3.0L 4WD Automatic | 4640 |

(1) Properly equipped.

Trailer Towing Applications

| Engine | Axle Ratios | Maximum Trailer Weight (lbs.) |
|----------------------------------|-------------|--|
| Duratec 23 - 2.3L (140) SEFI I-4 | All | 1500 |
| Duratec 30 - 3.0L (181) SEFI V-6 | All | 2000 (without Class II Trailer Towing Package) |
| | | 3500 (with Class II Trailer Towing Package) |

Escape

Required Equipment

- 3.0L (181) V-6 for trailers over 1500 lbs.
- 3.0L (181) V-6 and Class II Trailer Towing Package for trailers over 2000 lbs.

Trailer Towing Package Content

- 4-pin Trailer Wiring Harness and 4-pin Connector
- Hitch Receiver (weight-carrying capacity — 3500 lbs.)

Special Applications

Trailer Towing Information

NOTE: For additional towing information please refer to the 2005 RV & Trailer Towing Guide (found behind the 2005 Truck Source Book Towing tab) or the vehicle's Owner's Guide.

Snowplow Information

NOTE: Escape is not recommended for snowplow applications.

This page is about:

- Maximum Allowable Weight
- Cargo/Payload GVWR Worksheet

Maximum Allowable Weight (lbs.) (Regular Production Options and Aftermarket Equipment)

| Model | GVWR | 2.3L (140) DOHC I-4 Manual Transmission | 2.3L (140) DOHC I-4 Automatic Transmission | 3.0L (181) DOHC V-6 |
|-------|------|---|--|---------------------|
| FWD | 4300 | 197 | — | — |
| | 4360 | — | 184 | — |
| | 4500 | — | — | 280 |
| 4WD | 4460 | 194 | — | — |
| | 4520 | — | 193 | — |
| | 4640 | — | — | 247 |

Total Actual Regular Production Option Content Weight Cargo/Payload GVWR Worksheet

Escape

| Option Weight | (Front/Total) (lbs.) |
|---|-------------------------|
| WHEELS: | |
| 15 x 6.5" 5-Spoke Cast Aluminum | (-10/-19) |
| 16 x 7" 5-Spoke Cast Aluminum | (-6/-12) |
| 16 x 7" 5-Spoke Painted Alum (Blast) | (-7/-14) |
| 16 x 7" 5-Spoke Cast Aluminum Wide Spoke | (-4/-7) |
| 16 x 7" 5-Spoke Cast Alum Bright Machined | (-4/-7) |
| 16 x 6.5" Steel Full Size Dissimilar Spare | (0/3) |
| 16 x 7" Alum 5-Spoke Dissimilar Blk. Full Size Spare | (0/2) |
| 16 x 7" 5-Spoke Cast Alum Full Size Spare | (0/-2) |
| 16 x 7" 5-Spoke Cast Alum Wide Spoke Full Size Spare | (0/-1) |
| 16 x 7" 5-Spoke Cast Alum Bright Machined Full Size Spare | (0/-1) |
| TIRES: | |
| P235/70R16 BSW All-Season Full Size Spare | (-2/17) |
| P215/70R16 BSW A-S H-Rated Full Size Spare | (-1/10) |
| T135/90R17 Mini Spare | (0/-1) |
| OPTIONS: | |
| Air Curtain Restraint | (4/9) |
| Dynamic Side Impact | (4/8) |
| Power 6-Way Driver Seat High Cloth Series | (7/14) |
| Power 6-Way Driver Seat Leather | (9/19) |
| Heated Seats | (2/6) |
| Rear Recovery Bracket | (-2/6) |
| Ocean Shipping Bracket | (1/1) |
| Lowline Stereo/Cassette | (-2/-2) |
| Radio Delete | (-5/-6) |
| 7 Radio Speaker System | (0/14) |
| Subtotal: Front/Total | ___ / ___ |

| Option Weight | (Front/Total) (lbs.) |
|---|-------------------------|
| OPTIONS cont'd | |
| Automatic Headlamps | (1/1) |
| Front Fog Lamps | (4/3) |
| Side Repeater Lamps | (1/1) |
| Wheel Lip Molding | (3/4) |
| Side Step Bars | (15/38) |
| Locking Fuel Cap | (0/1) |
| Roof Rub Strips | (0/2) |
| No Boundaries Roof Rack | (10/30) |
| Roof Rack Less Horizontal Cross Bars | (-2/-4) |
| Heated Mirrors | (1/1) |
| Electrochromatic Rearview Mirrors | (1/1) |
| Moon Roof | (13/36) |
| Perimeter Alarm | (0/1) |
| Engine Block Heater | (1/1) |
| Reverse Sensing System | (0/2) |
| Less Air Conditioning | (-33/-34) |
| Overhead Console with Dual Storage Bins | (6/6) |
| Overhead Console with Single Storage Bin | (5/5) |
| Dual Mirror Lighted Visor | (1/1) |
| Cargo Cover, Retractable | (-1/7) |
| Floor mats | (3/7) |
| Leather-Wrapped Steering Wheel | (1/1) |
| Speed Control | (15/5) |
| Cargo Management System | (0/1) |
| Power 4-wheel Disc Brakes | (11/19) |
| Class II Trailer Tow with Hitch | (-6/20) |
| Subtotal: Front/Total | / |
| Subtotal: From 1st Col. | / |
| Line A: Total Actual Option Content/Weight: | ___ / ___ |

NOTE: Refer to the Payload Workbook section of the 2005 Appendices book.

2005 Escape

GVWR, Towing and Powertrains

GVWR, TOWING AND POWERTRAINS

This page is about:

Hitch Receiver Weight Capacity —
Recreational Neutral Towing —

Hitch Receiver Weight Capacity

| Vehicle | Weight-carrying Capacity (lbs.) ⁽¹⁾ | Max. Tongue Load (lbs.) | Weight-distributing Capacity (lbs.) | Max. Tongue Load (lbs.) |
|-----------------|--|-------------------------|-------------------------------------|-------------------------|
| Hitch Receiver: | | | | |
| Escape | 3500 | 300 | — | — |

(1) Ford hitch receivers do not include a hitch ball. The vehicle owner is responsible for obtaining the proper hitch ball, ball mounting and other appropriate equipment to tow both the trailer and its cargo load.

Recreational Neutral Towing

| Ford Vehicle | Can It Be Neutral Towed? |
|-------------------------------------|--------------------------|
| Escape | |
| 2.3L FWD/4WD Manual Transmission | Yes |
| 2.3L FWD/4WD Automatic Transmission | No |
| 3.0L FWD/4WD Automatic Transmission | No |

NOTE: For additional towing information please refer to the 2005 RV & Trailer Towing Guide (found behind the 2005 Truck Source Book Towing tab) or the vehicle's Owner's Guide.

2005 Escape

Dimensions

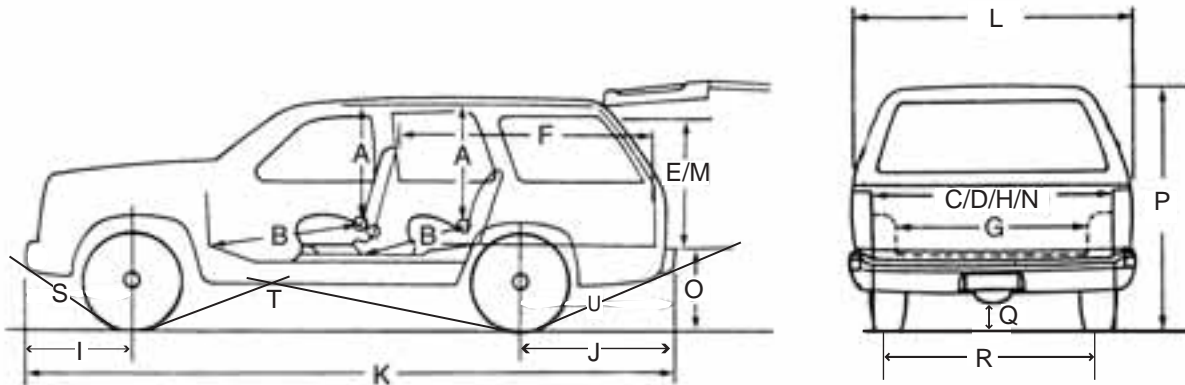

DIMENSIONS

| Wheelbase (in.) | | 103.1 |
|-----------------|--|-----------|
| Code | Description | Inches |
| A | Head Room (Front row) | 40.4 |
| | Head Room (Second row) | 39.2 |
| B | Leg Room (Front row) | 41.6 |
| | Leg Room (Second row) | 35.6 |
| C | Shoulder Room (Front row) | 56.3 |
| | Shoulder Room (Second row) | 55.9 |
| D | Hip Room (Front row) | 53.4 |
| | Hip Room (Second row) | 49.1 |
| E | Cargo Height, Maximum | 38.9 |
| F | Cargo Length @ Floor (Rear Seat Upright) | 35.9 |
| | Cargo Length @ Floor (Rear Seat Folded Down) | 59.0 |
| G | Cargo Width @ Wheelhouse | 40.8 |
| H | Cargo Width @ Floor | 52.6 |
| I | Front Overhang | 34.0 |
| J | Rear Overhang | 37.7 |
| K | Vehicle Length | 174.9 |
| L | Vehicle Width excluding mirrors | 70.1 |
| M | Cargo Rear Opening Height | 34.9 |
| N | Rear Opening Width at Floor | 41.0 |
| O | Cargo Floor Height To Ground (Empty) ⁽¹⁾ | 29.8 |
| P | Vehicle Height with Roof Rack (Empty) ⁽¹⁾ | 69.7 |
| Q | Ground Clearance | 8.0 |
| R | Front/Rear Track | 61.3/60.9 |
| S | Angle of Approach | 20.4° |
| T | Ramp Breakover Angle | 20.6° |
| U | Angle of Departure | 27.2° |

(1) The height data shown represents dimensions of a nominal vehicle with no options. Actual height may vary due to production tolerances.

2005 Escape

ESCAPE

Dimensions cont'd

FUEL TANK CAPACITY

| Engine | Availability | Location | Capacity (gallons) |
|--------|-----------------------|----------|--------------------|
| All | Standard Tank (Steel) | Midship | 16.5 / 62L |

VOLUMES

| Cargo Volume | Cubic Feet |
|---|------------|
| Behind Second Row | 29.3 |
| Behind First Row (second-row seat cushion in place) | 62.5 |
| Behind First Row (second-row seat cushion removed) | 66.3 |

BASE CURB WEIGHTS

| Model | Engine | GVWR (lbs.) | Front (lbs.) | Rear (lbs.) | Total (lbs.) |
|-------|-----------------|-------------|--------------|-------------|--------------|
| FWD | 2.3L I-4/Manual | 4300 | 1878 | 1305 | 3183 |
| | 2.3L I-4/Auto | 4360 | 1958 | 1298 | 3256 |
| | 3.0L V-6/Auto | 4500 | 2018 | 1282 | 3300 |
| 4WD | 2.3L I-4/Manual | 4460 | 1932 | 1414 | 3346 |
| | 2.3L I-4/Auto | 4520 | 2006 | 1401 | 3407 |
| | 3.0L V-6/Auto | 4640 | 2085 | 1407 | 3492 |

2005 Escape

Seating Capability and Standard Equipment Specifications

ESCAPE (103.1" WB)

| | | | | |
|--------------------------------------|--|---|---------------------------|---|
| DRIVE: | | Front-wheel Drive | | Four-wheel Drive |
| GVWR: (lbs.) | — Computer Selected (Not Published In Advertising) | 4300 (manual trans.) | 4360, 4500 (auto. trans.) | 4460 (manual trans.) 4520, 4640 (auto. trans.) |
| PASSENGER CAPACITY | | 5 | 5 | 5 5 |
| SEATING ARRANGEMENTS INCLUDE: | | | | |
| Low Back Bucket Seats | | ■ | ■ | ■ ■ |
| 60/40 Split Bench Seat (3-Pass.) | | ■ | ■ | ■ ■ |
| PASSENGER CAPACITY (lbs.) | | 750 | 750 | 750 750 |
| CARGO CAPACITY (Max.) (lbs.) | | 245 | 245, 325 | 260 260, 305 |
| GAWR (lbs.): | | | | |
| Front | — Min. | 2240 | 2320, 2380 | 2320 2380, 2440, 2440 |
| | — Max. | 2240 | 2320, 2380 | 2320 2380, 2440, 2440 |
| Rear | — Min. | 2190 | 2190, 2250 | 2290 2290-2330, 2330 |
| | — Max. | 2190 | 2190, 2250 | 2290 2290-2330, 2330 |
| POWERTRAIN: | | | | |
| Engine | — Application | Refer To Dealer Ordering Guide For 50 States Usage | | |
| | — Type (Min.) | 2.3L I-4 | 3.0L V-6 | 3.0L V-6 |
| Transmission | — Type (Min.) | Manual | Automatic | Automatic |
| | — Speeds | 5-Speed Overdrive | 4-Speed Overdrive | 4-Speed Overdrive |
| Clutch | — Diameter | 8.86" | — | — |
| 4x4 System | — Type | — | — | Intelligent 4WD System |
| | — 4x4 Mode | — | — | 4x4 AUTO—Splits Torque On Demand |
| | — Front/Rear Torque Proportioning Device | — | — | Power Transfer Unit mounted to transaxle transfers power to the rear axle through 2-piece driveshaft. Electromagnetic Coupling located between end of the driveshaft and Rear Axle Differential governs Front/Rear Torque Split |
| BRAKES: | | | | |
| Front Disc | — Type | Single Piston Pin-Slider, Bolt-on Anchor Caliper | | |
| | — Size | 10.9" Diameter 11.9" Diameter (V-6) | | |
| Rear Drum | — Type | Self-Adjusting | | |
| | — Size | 9.0" Diameter | | |
| Rear Disc (V-6 4WD only) | — Type | Self-Adjusting | | |
| | — Size | 9.0" Diameter 11.9" Diameter (V-6) | | |
| Power Assist Unit | — Type | Dual-Diaphragm | | |
| | — Effective Dia. | 8.0" | | |
| Anti-lock System | | 4-Channel, 4-Wheel ABS With Electronic Brake Force Distribution | | |
| Parking Brake (Rear Brakes) | | Lever-Type, Hand-Operated, Hand Release | | |
| ELECTRICAL: | | | | |
| Alternator | — Rating | 110 Amperes, 1650 Watt (6G) | | |
| Battery | — Type | Maintenance-Free (Battery Saver System Standard) | | |
| | — Rating | 52 Amp-hr., 550 CCA | 60 Amp-hr., 590 CCA | 60 Amp-hr., 590 CCA |
| FRAME: | — Type | Unitized Body Structure | | |
| FUEL TANK, MIDSHIP: | — Capacity | 16.5 Gal. (62L) | | |

Seating Capability and Standard Equipment Specifications cont'd

ESCAPE (103.1" WB) cont'd

| | | | | | |
|---------------------|--|--|------------|------------------|-----------------|
| DRIVE: | | Front-wheel Drive | | Four-wheel Drive | |
| GVWR: (lbs.) | — Computer Selected (Not Published In Advertising) | 4300 | 4360, 4500 | 4460 | 4520, 4640 |
| STEERING: | — Type | Power, Rack-And-Pinion | | | |
| | — Ratio | 17.9:1 | 17.9:1 | 17.9:1 | |
| SUSPENSION: | | | | | |
| Suspension, Front | — Type | Independent, MacPherson Struts Attached To Lower Control Arms (Dual Path Upper Strut Mount With Strut And Coil Spring Mounted Separately) And Front Stabilizer Bar | | | |
| | — Capacity (lbs.) | 2480 | | 2480 | |
| | — Spring Rating (lbs.) | 2240 | 2320, 2380 | 2320 | 2380-2440, 2440 |
| | — Stabilizer Bar | Standard | | | |
| Suspension, Rear | — Type | Independent, Double Lateral Link And Semi-Trailing Arms (Coil Springs Located Between Trailing Arms And Body) | | | |
| | — Capacity (lbs.) | 2400 | | 2440 | |
| | — Spring Rating (lbs.) | 2190 | 2190, 2250 | 2290 | 2290-2330, 2330 |
| TIRES: | — No./Type | Four, Steel-Belted Radial, All-Season | | | |
| | — Size | P225/75R15 BSW | | | |
| | — Spare Tire | T145/90R17 Temporary (Stowed Under Rear of vehicle on winch system) | | | |
| WHEELS: | — No./Type | Four, 5-Hole Disc, 5-Spoke | | | |
| | — Type | Styled Steel | | | |
| | — Size | 15" x 6.5" | | | |
| | — Spare Wheel | Steel, 17" x 4.0" Temporary (Stowed Under Rear of vehicle on winch system) | | | |

2005 Escape

Technical Specifications

Brakes

HYDRAULIC BRAKE EQUIPMENT SPECIFICATIONS — FRONT DISC

| Type | Rotor Dia. (in.) | | Brake Lining Segment | Area (sq. in.)/ Width (in.)/ Thickness (in.) | Caliper Piston Dia. (in.) | Gross Lining Area Per Axle (sq. in.) | Total Swept Area Per Axle (sq. in.) |
|------|------------------|------|----------------------|--|---------------------------|--------------------------------------|-------------------------------------|
| | OD | ID | | | | | |
| Disc | 10.94 | 6.41 | Outboard | 8.1/4.09/.50 | Single 2.36 | 32.40 | 232.02 |
| | | | Inboard | | | | |

HYDRAULIC BRAKE EQUIPMENT SPECIFICATIONS — REAR DRUM

| Type | Brake Size (in.) | Lining Thickness (in.) | | Wheel Cylinder Dia. (in.) | Gross Lining Area Per Axle (sq. in.) | Total Swept Area Per Axle (sq. in.) |
|------|------------------|------------------------|-----------|---------------------------|--------------------------------------|-------------------------------------|
| | | Primary | Secondary | | | |
| Drum | 9.0 x 1.65 | .177 | .177 | 0.937 | 59.76 | 93.57 |

HYDRAULIC BRAKE EQUIPMENT SPECIFICATIONS — REAR DISC

| Type | Rotor (in.) | | | Park Brake Hat (in.) | Brake Lining Segment | Area (sq. in.)/ Width (in.)/ Thickness (in.) | Caliper Piston Dia. (in.) | Gross Lining Area Per Axle (sq. in.) | Total Swept Area Per Axle (sq. in.) |
|------|-------------|------|-----------|----------------------|----------------------|--|---------------------------|--------------------------------------|-------------------------------------|
| | OD | ID | Thickness | | | | | | |
| Disc | 11.88 | 8.19 | 0.47 | 7.28 | 1.18 | Outboard | Single 2.36 | 32.40 | 232.02 |
| | | | | | | Inboard | | | |

BRAKE MASTER CYLINDER SPECIFICATIONS

| Type | Bore Dia. (in.) |
|---------------------------|-----------------|
| Dual System, Dash Mounted | 1.00 |

POWER BRAKES VACUUM BOOSTER SPECIFICATIONS

| Make/Type | Effective Dia. (in.) | Diaphragm Type |
|--------------|----------------------|----------------|
| Dash Mounted | 8.00 | Dual |

Cooling Systems

COOLING SYSTEM SPECIFICATIONS

| Engine | Cooling | Trans. Usage | Frontal Area (sq. in.) | Core Size (in.) | | | Rows of Tubes | Fins Per Inch | Cooling System Capacity (approx. qts.) | Fan Specifications | |
|----------------|---------|--------------|------------------------|-----------------|-------|--------|---------------|---------------|--|--------------------|---------------------------------|
| | | | | Height | Width | Thick. | | | | Number/ Watts | Blade Dia. (in.) ⁽¹⁾ |
| 2.3L (140) I-4 | Std. | Man. | 506 | 18.38 | 27.56 | 1.02 | 41 | 85 | — | Dual 80 Watt | 12.59 |
| 2.3L (140) I-4 | Std. | Auto. | 506 | 18.38 | 27.56 | 1.02 | 41 | 85 | — | Dual 80 Watt | 12.59 |
| 3.0L (181) V-6 | Std. | Auto. | 506 | 18.46 | 27.56 | 1.02 | 41 | 85 | — | Dual 320 Watt | 12.59 |

(1) 5-blade fan on L.H. side and 6-blade fan on R.H. side.

Fuel System

FUEL SYSTEM DATA

| | | |
|---------------------------|--------------------------|-------------------------------------|
| Electronic Fuel Injection | 2.3L (138) I-4 (Duratec) | Sequential Multiport Fuel Injection |
| | 3.0L (183) V-6 (Duratec) | Sequential Multiport Fuel Injection |

Technical Specifications cont'd

Steering

STEERING SPECIFICATIONS

| Engine | Tire Size | Power Steering | Turning Diameter (ft.) | |
|----------------|------------|----------------|------------------------|--------------|
| | | Gear Ratio | Curb-to-Curb | Wall-to-Wall |
| 2.3L (138) I-4 | P225/75R15 | 17.9:1 | 35.4 | 38.7 |
| 3.0L (183) V-6 | P235/70R16 | 17.9:1 | 36.7 | 40.1 |
| 2.3L (138) I-4 | T145/90R17 | 17.9:1 | 36.7 | 40.1 |
| 3.0L (183) V-6 | T185/60R17 | 17.9:1 | 36.7 | 40.1 |

Suspensions

SUSPENSION, FRONT

| Model | Front-wheel Drive | Four-wheel Drive |
|------------------------|--|------------------|
| Type | Independent, MacPherson Struts Attached To Lower Control Arms (Dual Path Upper Strut Mount With Strut And Coil Spring Mounted Separately) And Front Stabilizer Bar | |
| Capacity (lbs.) | 2480 | 2480 |

SUSPENSION, REAR

| Model | Front-wheel Drive | Four-wheel Drive |
|------------------------|---|------------------|
| Type | Independent, Double Lateral Link And Semi-Trailing Arms (Coil Springs Located Between Trailing Arms And Body) | |
| Capacity (lbs.) | 2348 | 2348 |

Tires and Wheels

TIRE SPECIFICATIONS

| Size | Rim Width (in.) | Section Width (in.) | Load/Ply Rating | Max. Inflation Pressure (psi) | Load Limits @ Max. Inflation Pressure (lbs.) | Static Loaded Radius (in.) | Revolutions Per Mile @ 45 mph |
|--|-----------------|---------------------|-----------------|-------------------------------|--|----------------------------|-------------------------------|
| P225/75R15 All-Season BSW | 6.5 | 9.06 | Std. | 44 | 1753 | 12.96 | 759 |
| P235/70R16 All-Season BSW/OWL | 7.0 | 9.09 | Std. | 44 | 1984 | 13.30 | 728 |
| P235/70R16 All-Terrain OWL | 7.0 | 9.09 | Std. | 44 | 1984 | 13.30 | 728 |
| T145/90R17 Temporary Mini Spare ⁽¹⁾ | 4.0 | 5.8 | Std. | 60 | 1653 | 12.62 | 738 |
| T185/60R17 Temporary Mini Spare ⁽²⁾ | 5.0 | 7.6 | Std. | 60 | 1874 | 11.8 | 793 |
| P235/70R16 A/S Dissimilar Temporary Full Size Spare ⁽³⁾ | 7.0 | 9.4 | Std. | 44 | 1984 | 13.2 | 721 |

(1) Used with 15" Road Tire.

(2) Used with 16" Road Tire, V-6, 4x2.

(3) Used with 16" Road Tire, V-6, 4x4.

WHEEL SPECIFICATIONS

| Wheel Type | Wheel Size | Inset (in.) | No. of Studs | Bolt Circle (in.) | Max. Wheel Capacity Load (lbs. @ ground) |
|--|--------------|-------------|--------------|-------------------|--|
| 5-Spoke Styled Steel (XLS) | 15" x 6.5" J | 1.77 | 5 | 4.49 | 1240 |
| 5-Spoke Cast Aluminum (XLS) | 15" x 6.5" J | 1.77 | 5 | 4.49 | 1240 |
| 5-Spoke Cast Aluminum (XLT) | 16" x 7.0" J | 1.77 | 5 | 4.49 | 1240 |
| 5-Spoke Painted Aluminum (XLT No Boundaries) | 16" x 7.0" J | 1.77 | 5 | 4.49 | 1240 |
| 5-Spoke Bright Machined Aluminum (XLT Sport, Limited) | 16" x 7.0" J | 1.77 | 5 | 4.49 | 1240 |
| Steel Spare (Temporary) ⁽¹⁾ | 17" x 4.0" T | 1.77 | 5 | 4.49 | 1240 |
| Steel Spare (Temporary) ⁽²⁾ | 17" x 5.0" T | 1.77 | 5 | 4.49 | 1240 |
| 5-Spoke Dissimilar Black Painted Aluminum Spare (Temporary) ⁽³⁾ | 16" x 7.0" T | 1.77 | 5 | 4.49 | 1240 |

(1) Used with 15" Road Wheel.

(2) Used with 16" Road Wheel, V-6, 4x2.

(3) Used with 16" Road Wheel, V-6, 4X4.

2005 Escape

Technical Specifications cont'd

Transmissions

MANUAL TRANSMISSION SPECIFICATIONS

| Make/Type | Mazda (5-Speed Overdrive) (G5M) | | |
|--------------------------|---------------------------------|-------|--|
| Ratios (to 1): | | | |
| 1st | | | 3.666 |
| 2nd | | | 2.058 |
| 3rd | | | 1.310 |
| 4th | | | 1.030 |
| 5th | | | 0.837 |
| Reverse | | | 3.454 |
| Lubricant Capacity (pt.) | | | 5.74 (4.68 With 4x4) |
| Synchronizers | | | All Gears |
| Gears: Material | | | Carburized Steel |
| Type | | | Helical (Forward Gears) Spar (Reverse Gear) |
| Bearings: | | | |
| Mainshaft | — | Front | Single Row Taper |
| | — | Rear | Single Row Taper |
| Countershaft Gear | — | Front | Single Row Taper |
| | — | Rear | Single Row Taper |
| Reverse Idler Gear | | | Bushing |

AUTOMATIC TRANSMISSION SPECIFICATIONS

| Make/Type | Ford (4-Speed Automatic Overdrive) (CD4E) ⁽¹⁾ | | |
|--------------------------|--|--|--------------------------------------|
| Ratios (to 1): | | | |
| 1st | | | 2.889 |
| 2nd | | | 1.571 |
| 3rd | | | 1.000 |
| 4th — OD | | | 0.698 |
| Reverse | | | 2.310 |
| Converter | | | 2.072 |
| Lubricant Capacity (pt.) | | | 18.5 (12.3 Without Torque Converter) |
| Helical Gears | | | All |
| Converter Size & Type | | | 9.25" Lock-up |

(1) Includes auxiliary oil cooler.

CLUTCH SPECIFICATIONS

| Engine | 2.3L (140) I-4 |
|--------------------------------|--|
| Actuation | Hydraulic Clutch Control |
| Disc — Type | Segmented With Spring Vibration Damper |
| Lining Material | Semi-mold Non-Asbestos |
| Outside Diameter (approx. in.) | 8.86 |
| Inside Diameter (in.) | 5.91 |
| Facing Area (sq. in.) | 68.4 |
| Facing Thickness (in.) | .138 |
| Pressure Plate — Make | Luk |
| Total Plate Pressure (lb.) | 1102 |